

MENIIT

NEET | IIT-JEE | FOUNDATION

Corporate Office: 44-A/1, Kalu Sarai, New Delhi 110016 | **Web:** www.meniit.com

JEE MAIN-2021

COMPUTER BASED TEST (CBT)

DATE : 25-02-2021 (EVENING SHIFT) | TIME : (3.00 pm to 6.00 pm)

Duration 3 Hours | Max. Marks : 300

QUESTION & SOLUTIONS

PART A : PHYSICS

Single Choice Type

This section contains **20 Single choice questions**. Each question has 4 choices (1), (2), (3) and (4) for its answer, out of which **Only One** is correct.

1. For extrinsic semiconductors; when doping level is increased;
- (1) Fermi-level of p-type semiconductor will go upward and Fermi-level of n-type semiconductors will go downward.
 - (2) Fermi-level of p-type semiconductors will go downward and Fermi-level of n-type semiconductor will go upward.
 - (3) Fermi-level of both p-type and n-type semiconductors will go upward for $T > T_F$ K and downward for $T < T_F$ K, where T_F is Fermi temperature.
 - (4) Fermi-level of p and n-type semiconductors will not be affected.

Ans. (2)

Sol. (2) conceptual

2. In a ferromagnetic material, below the curie temperature, a domain is defined as :
- (1) a macroscopic region with zero magnetization.
 - (2) a macroscopic region with consecutive magnetic dipoles oriented in opposite direction.
 - (3) a macroscopic region with randomly oriented magnetic dipoles.
 - (4) a macroscopic region with saturation magnetization.

Ans. (4)

Sol. (4) conceptual

3. Thermodynamic process is shown below on a P-V diagram for one mole of an ideal gas. If $V_2 = 2V_1$ then the ratio of temperature T_2/T_1 is :

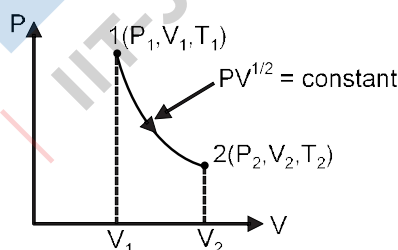

(1) $\frac{1}{2}$

(2) 2

(3) $\sqrt{2}$

(4) $\frac{1}{\sqrt{2}}$

Ans. (3)

Sol. $PV^{1/2} = c$

$$\frac{nRT}{V} V^{1/2} = c$$

$$T = c^1 V^{1/2}$$

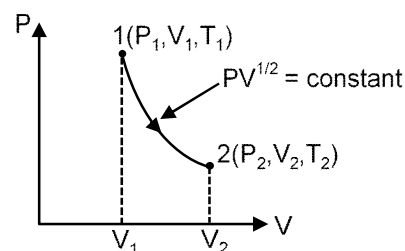

$$\frac{T_2}{T_1} = \frac{V_2}{V_1}^{\frac{1}{2}} = \frac{2V_1}{V_1}^{\frac{1}{2}}$$

$$\frac{T_2}{T_1} = \sqrt{2}$$

4. A stone is dropped from the top of a building. When it crosses a point 5 m below the top, another stone starts to fall from a point 25 m below the top. Both stones reach the bottom of building simultaneously. The height of the building is :
- (1) 35 m (2) 45 m (3) 50 m (4) 25 m

Ans. (2)

Sol. Time for particle to meet $t' = \frac{S_{rel}}{S_{rel}} = \frac{20}{10} = 2 \text{ sec.}$

Time taken by 1st particle to reach ground = 3sec

$$H = \frac{1}{2}g(3)^2 = 45 \text{ m}$$

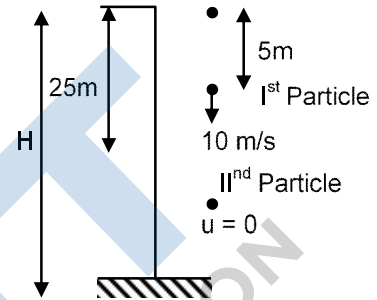

5. Given below are two statements :

Statement I : In a diatomic molecule, the rotational energy at a given temperature obeys Maxwell's distribution.

Statement II : In a diatomic molecule, the rotational energy at a given temperature equals the translational kinetic energy for each molecule.

In the light of the above statements, choose the correct answer from the options given below :

- (1) Statement I is false but Statement II is true. (2) Both Statement I and Statement II are false.
 (3) Both Statement I and Statement II are true. (4) Statement I is true but Statement II is false.

Ans. (4)

Sol. (4) Translational degree of freedom = 3
 Rotational degree of freedom = 2

6. Two identical springs of spring constant '2k' are attached to a block of mass m and to fixed support (see figure). When the mass is displaced from equilibrium position on either side, it executes simple harmonic motion. The time period of oscillations of this system is :

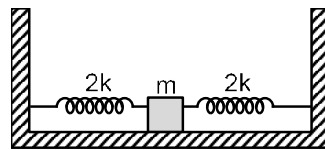

- (1) $2\sqrt{\frac{m}{k}}$ (2) $\sqrt{\frac{m}{2k}}$ (3) $2\sqrt{\frac{m}{2k}}$ (4) $\sqrt{\frac{m}{k}}$

Ans. (4)

Sol. (4) For parallel combination $k_{eq} = k_1 + k_2$
 $k_{eq} = 4k$

$$T = 2\sqrt{\frac{m}{k_{eq}}}$$

7. If a message signal of frequency ' f_m ' is amplitude modulated with a carrier signal of frequency ' f_c ' and radiated through an antenna, the wavelength of the corresponding signal in air is :

- (1) $\frac{c}{f_c f_m}$ (2) $\frac{c}{f_m}$ (3) $\frac{c}{f_c}$ (4) $\frac{c}{f_c}$

Ans. (4)

Sol. (4) $\frac{v}{f} = \frac{c}{f_c}$

8. A charge ' q ' is placed at one corner of a cube as shown in figure. The flux of electrostatic field \vec{E} through the shaded area is :

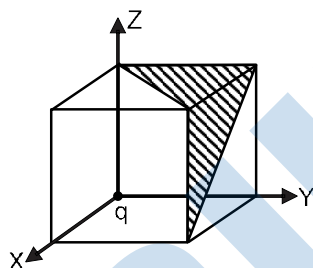

- (1) $\frac{q}{4 \epsilon_0}$ (2) $\frac{q}{24 \epsilon_0}$ (3) $\frac{q}{48 \epsilon_0}$ (4) $\frac{q}{8 \epsilon_0}$

Ans. (2)

Sol. flux through cube $\frac{q}{8 \epsilon_0}$

flux through surfaces ABEH, ADGH, ABCD will be zero

(EFGH) (DCFG) (EBCF) $\frac{1}{3} \frac{q}{8 \epsilon_0}$

$\frac{q}{24 \epsilon_0}$

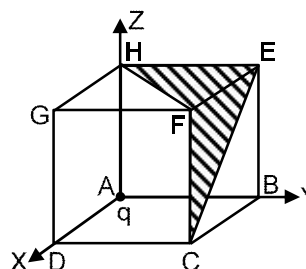

9. The wavelength of the photon emitted by a hydrogen atom when an electron makes a transition from $n = 2$ to $n = 1$ state is :

- (1) 194.8 nm (2) 913.3 nm (3) 490.7 nm (4) 121.8 nm

Ans. (4)

Sol. $\frac{1}{\lambda} = R \left(\frac{1}{1^2} - \frac{1}{2^2} \right)$

$\lambda = 121.8 \text{ nm.}$

10. An LCR circuit contains resistance of 110Ω and a supply of 220 V at 300 rad/s angular frequency. If only capacitance is removed from the circuit, current lags behind the voltage by 45° . If on the other hand, only inductor is removed the current leads by 45° with the applied voltage. The rms current flowing in the circuit will be :

- (1) 1A (2) 2.5 A (3) 1.5 A (4) 2A

Ans. (4)

Sol. $\tan 45 = \frac{1}{CR} = \frac{L}{R} = X_L = X_C$

\Rightarrow resonance

$$i = \frac{V}{R}$$

$$\frac{220}{110} = 2 \text{ A}$$

11. A sphere of radius 'a' and mass 'm' rolls along a horizontal plane with constant speed v_0 . It encounters an inclined plane at angle θ and climbs upward. Assuming that it rolls without slipping, how far up the sphere will travel ?

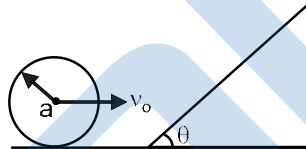

- (1) $\frac{10}{7} \frac{v_0^2}{g \sin \theta}$ (2) $\frac{2}{5} \frac{v_0^2}{g \sin \theta}$ (3) $\frac{2}{5} \frac{v_0^2}{g \sin \theta}$ (4) $\frac{2}{2g \sin \theta}$

Ans. (1)

Zigyan Ans. (BONUS)

Sol. Angular momentum conservation about A

$$mv_0 a \cos \theta = \frac{2}{5} ma^2 \omega$$

$$mva = \frac{2}{5} ma^2 \omega$$

$$mv_0 a \frac{2}{5} \cos \theta = \frac{7}{5} mva$$

$$v = \frac{7}{5} v_0 \frac{2}{5} \cos \theta$$

$$\frac{1}{2} mv^2 = \frac{1}{2} I \omega^2 = \frac{7}{10} mv^2 = mgh$$

No option Matching

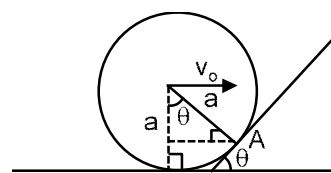

12. An electron of mass m_e and a proton of mass $m_p = 1836 m_e$ are moving with the same speed. The ratio of their de Broglie wavelength $\frac{\text{electron}}{\text{proton}}$ will be :

- (1) 1836 (2) 1 (3) 918 (4) $\frac{1}{1836}$

Ans. (1)

Sol. $\frac{e}{p} = \frac{\frac{h}{m_e v}}{\frac{h}{m_p v}} = 18.36$

13. $Y = A \sin(\omega t + \phi_0)$ is the time-displacement equation of a SHM. At $t = 0$ the displacement of the particle is $Y = \frac{A}{2}$ and it is moving along negative x-direction. Then the initial phase angle ϕ_0 will be :

- (1) $\frac{\pi}{6}$ (2) $\frac{\pi}{3}$ (3) $\frac{5\pi}{6}$ (4) $\frac{2\pi}{3}$

Ans. (3)

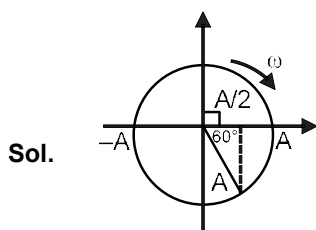

initial phase $\frac{\pi}{2} - \frac{\pi}{3} = \frac{5\pi}{6}$

14. If e is the electronic charge, c is the speed of light in free space and h is Planck's constant, the quantity

$\frac{1}{4\pi\epsilon_0} \frac{|e|^2}{hc}$ has dimensions of :

- (1) $[M^0 L^0 T^0]$ (2) $[L C^{-1}]$ (3) $[M L T^{-1}]$ (4) $[M L T^0]$

Ans. (1)

Sol. $F = \frac{1}{4\pi\epsilon_0} \frac{e^2}{r^2}$ $E = \frac{hc}{\lambda}$
 $\frac{e^2}{4\pi\epsilon_0 hc} = \frac{Fr^2}{E} = M^0 L^0 T^0$

15. An electron with kinetic energy K_1 enters between parallel plates of a capacitor at an angle ' α ' with the plates. It leaves the plates at angle ' β ' with kinetic energy K_2 . Then the ratio of kinetic energies $K_1 : K_2$ will be :

- (1) $\frac{\sin^2}{\cos^2}$ (2) $\frac{\cos^2}{\sin^2}$ (3) $\frac{\cos}{\sin}$ (4) $\frac{\sin}{\cos}$

Ans. (2)

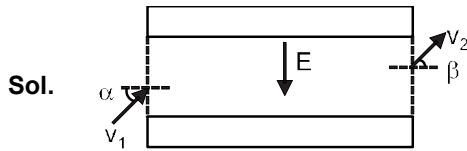

velocity along the plate will not change.

$$\therefore v_1 \cos \alpha = v_2 \cos \beta$$

$$\frac{K_1}{K_2} = \frac{v_1^2}{v_2^2} = \frac{\cos^2 \beta}{\cos^2 \alpha}$$

16. The point A moves with a uniform speed along the circumference of a circle of radius 0.36 m and covers 30° in 0.1 s. The perpendicular projection 'P' from 'A' on the diameter MN represents the simple harmonic motion of 'P'. The restoration force per unit mass when P touches M will be :

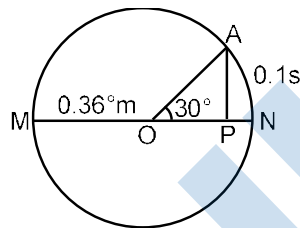

- (1) 100 N (2) 0.49 N (3) 50 N (4) 9.87 N

Ans. (4)

Sol. 30° → 0.1 s

$$360^\circ \rightarrow 1.2 \text{ s} = T$$

$$\frac{2}{T} = \frac{5}{3}$$

$$\text{At M, } F = m\omega^2 A = \frac{F}{m} \cdot A$$

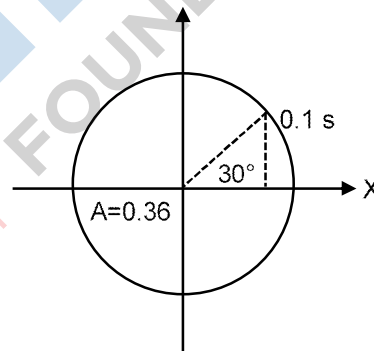

17. The truth table for the following logic circuit is :

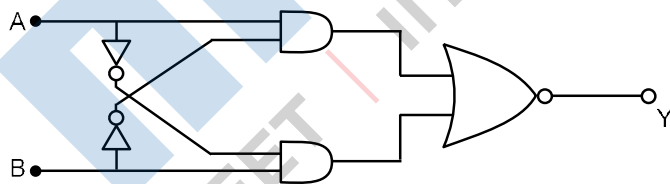

(1)

A	B	Y
0	0	0
0	1	1
1	0	1
1	1	0

(2)

A	B	Y
0	0	1
0	1	0
1	0	0
1	1	1

(3)

A	B	Y
0	0	1
0	1	0
1	0	1
1	1	0

(4)

A	B	Y
0	0	0
0	1	1
1	0	0
1	1	1

Ans. (2)

Sol. $y = \overline{A\bar{B}} \cdot \overline{\bar{A}B}$

$$y = \overline{A\overline{B}} \overline{A\overline{B}}$$

$$y = \overline{A} B A \overline{B}$$

$$y = \overline{A} A \overline{A\overline{B}} A B \overline{B\overline{B}}$$

$$y = AB \overline{A\overline{B}}$$

A	B	Y	AB	$\overline{A\overline{B}}$
0	0		1	
0	1		0	
1	0		0	
1	1		1	

18. The stopping potential for electrons emitted from a photosensitive surface illuminated by light of wavelength 491 nm is 0.710 V. When the incident wavelength is changed to a new value, the stopping potential is 1.43 V. The new wavelength is :

- (1) 329 nm (2) 309 nm (3) 382 nm (4) 400 nm

Ans. (3)

Sol. $\frac{hc}{\lambda} = eV_s$

$$\frac{1240}{491} = 0.71 \quad \dots(1)$$

$$\frac{1240}{\lambda} = 1.43 \quad \dots(2)$$

$$\therefore \lambda = 382 \text{ nm}$$

19. Match List I with List II.

List I	List II
(a) Rectifier	(i) Used either for stepping up or stepping down the a.c. voltage
(b) Stabilizer	(ii) Used to convert a.c. voltage into d.c. voltage
(c) Transformer	(iii) Used to remove any ripple in the rectified output voltage
(d) Filter	(iv) Used for constant output voltage even when the input voltage or load current change

Choose the correct answer from the options given below :

- (1) (a)–(ii), (b)–(iv), (c)–(i), (d)–(iii)
 (2) (a)–(iii), (b)–(iv), (c)–(i), (d)–(ii)
 (3) (a)–(ii), (b)–(i), (c)–(iv), (d)–(iii)
 (4) (a)–(ii), (b)–(i), (c)–(iii), (d)–(iv)

Ans. (1)

- Sol.** (a) Rectifier → AC to DC
(b) Stabilizer → used for constant output voltage even when input voltage or current change.
(c) Transformer → Step - up or step - down ac voltage.
(d) Filter → used to remove any ripple in the rectified output voltage.
- 20.** Consider the diffraction pattern obtained from the sunlight incident on a pinhole of diameter 0.1 mm. If the diameter of the pinhole is slightly increased, it will affect the diffraction pattern such that :
- (1) its size decreases, and intensity decreases
 - (2) its size increases, and intensity increases
 - (3) its size increases, but intensity decreases
 - (4) its size decreases, but intensity increases

Ans. (4)

Sol. $\sin \frac{m}{a}$

when a increases, θ decreases,

width decreases

width decreases so intensity will increase

Numeric Value Type

This Section contains **10 Numeric Value Type question**, out of 10 only 5 have to be done.

1. The peak electric field produced by the radiation coming from the 8 W bulb at a distance of 10 m is $\frac{x}{10} \sqrt{\frac{0c}{m}} \frac{V}{m}$. The efficiency of the bulb is 10% and it is a point source. The value of x is _____.

Ans. (2)

Sol. $I = \frac{1}{2} c_0 E_0^2$

$$\frac{8}{4 \cdot 10^2} = \frac{1}{2} \cdot \frac{1}{4} c_0 \frac{1}{c^2} E_0^2$$

$$E_0 = \frac{2}{10} \sqrt{\frac{0c}{m}} \cdot x \cdot 2$$

2. Two small spheres each of mass 10 mg are suspended from a point by threads 0.5 m long. They are equally charged and repel each other to a distance of 0.20 m. The charge on each of the sphere is $\frac{a}{21} \cdot 10^{-8} \text{C}$. The value of 'a' will be _____.

[Given $g = 10 \text{ ms}^{-2}$]

Ans. (20)

Sol. $T \cos \theta = mg = 10 \times 10^{-6} \times 10 = 10^{-4}$

$$T \sin \theta = \frac{9 \cdot 10^9 \cdot q^2}{0.04} = F$$

$$\tan \theta = \frac{0.1}{\sqrt{0.24}} = \frac{F}{mg}$$

$$q = \frac{2\sqrt{10}}{3\sqrt{\sqrt{24}}} \cdot 10^{-8}$$

$$0.95 \cdot 10^{-8} = \frac{a}{21} \cdot 10^{-8}$$

$$a = 20$$

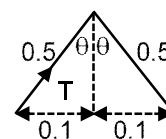

3. The initial velocity v_i required to project a body vertically upward from the surface of the earth to reach a height of 10 R, where R is the radius of the earth, may be described in terms of escape velocity v_e such that $v_i = \sqrt{\frac{x}{y}} v_e$. The value of x will be _____.

Ans. (10)

Sol. $\frac{GMm}{11R} = \frac{GMm}{R} - \frac{1}{2}mv^2$

$$v = \sqrt{\frac{20GM}{11R}}$$

4. The wavelength of an X-ray beam is 10Å. The mass of a fictitious particle having the same energy as that of the X-ray photons is $\frac{x}{3}$ h kg. The value of x is _____.

(h = Planck's constant)

Ans. (10)

Sol. $\frac{hc}{\lambda} = mc^2$

$$m = \frac{h}{c\lambda}$$

5. A reversible heat engine converts one-fourth of the heat input into work. When the temperature of the sink is reduced by 52 K, its efficiency is doubled. The temperature in Kelvin of the source will be _____.

Ans. (208)

Sol. $\frac{1}{4} = 1 - \frac{T_2}{T_1}$

$$\frac{T_2}{T_1} = \frac{3}{4}$$

$$\frac{T_2 - 52}{T_1} = \frac{1}{2}$$

6. The percentage increase in the speed of transverse waves produced in a stretched string if the tension is increased by 4%, will be _____ %.

Ans. (2)

Sol. $v \propto \sqrt{T}$

$$\frac{V}{V} = \frac{1}{2} \frac{T}{T}$$

7. If $\vec{P} \cdot \vec{Q} = \vec{Q} \cdot \vec{P}$, the angle between \vec{P} and \vec{Q} is θ ($0^\circ < \theta < 360^\circ$). The value of ' θ ' will be _____°.

Ans. (180)

Sol. $-\vec{P} \cdot \vec{Q} \sin \theta$

$$= \vec{P} \cdot \vec{Q} \sin \theta$$

$$\Rightarrow \theta = 180^\circ$$

8. Two identical conducting spheres with negligible volume have 2.1 nC and -0.1 nC charges, respectively. They are brought into contact and then separated by a distance of 0.5 m. The electrostatic force acting between the spheres is _____ $\times 10^{-9}$ N.

[Given : $\frac{1}{4\pi\epsilon_0} = \frac{1}{9 \times 10^9}$ SI unit]

Ans. (36)

Sol. $q = \frac{(2.1 \times 0.1)}{2} \text{ nC} = 1 \text{ nC}$

$f = \frac{9 \times 10^9 \times 10^{-18}}{(0.5)^2} = 36 \times 10^9$

9. A current of 6 A enters one corner P of an equilateral triangle PQR having 3 wires of resistance 2Ω each and leaves by the corner R. The currents i_1 in ampere is _____.

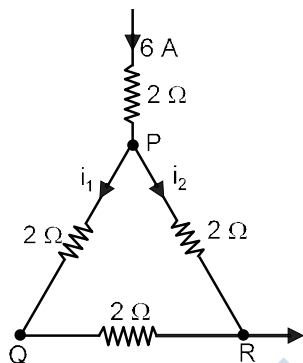

Ans. (2)

Sol. For parallel combination current divides in the inverse ratio of resistance.

$i_{PQ} = \frac{2}{6} \times 6 \text{ A}$

10. Two particles having masses 4 g and 16 g respectively are moving with equal kinetic energies. The ratio of the magnitudes of their linear momentum is $n : 2$. The value of n will be _____.

Ans. (1)

Sol. $\frac{p_1^2}{2 \times 4} = \frac{p_2^2}{2 \times 16}$

$\frac{p_1}{p_2} = \frac{1}{2}$

PART B : CHEMISTRY

Single Choice Type

This section contains **20 Single choice questions**. Each question has 4 choices (1), (2), (3) and (4) for its answer, out of which **Only One** is correct.

1. Which among the following species has unequal bond lengths ?

- (1) BF_4^- (2) XeF_4 (3) SF_4 (4) SiF_4

Ans. (3)

Sol.

Species	Hybridisation	Bond length
BF_4^-	sp^3 (Tetrahedral)	All bond lengths equal
XeF_4	sp^3d^2 (sq. planar)	All bond lengths equal
SF_4	sp^3d (see – saw)	Axial bond length > equatorial bond length
SiF_4	sp^3 (Tetrahedral)	All bond lengths equal

2. Carbyl amine test is used to detect the presence of primary amino group in an organic compound. Which of the following compound is formed when this test is performed with aniline?

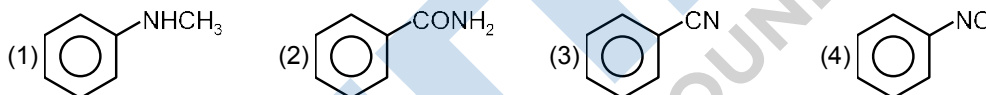

Ans. (4)

Sol. CARBYL amine given by 1° amine

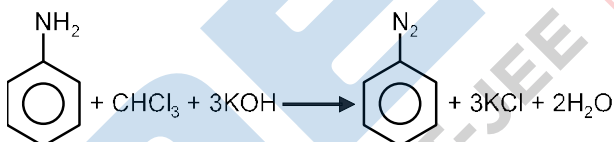

3. Which of the following is correct structure of α -anomer of maltose ?

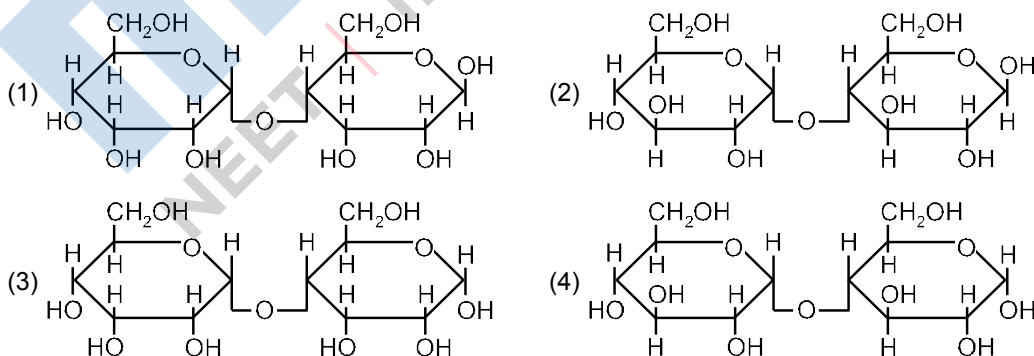

Ans. (4)

Sol. α -ANOMER OF MALTOSE

maltose is disaccharides of α -D-glucopyranose by C₁-C₄ glycosidic linkage

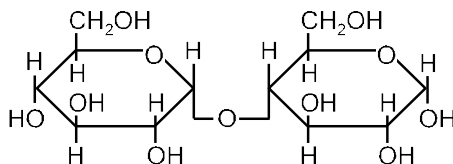

4. The major product of the following reaction is:

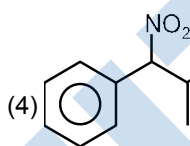
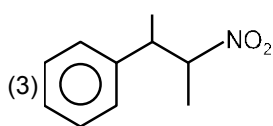
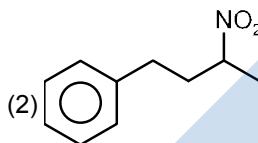
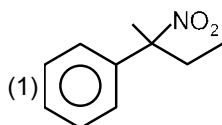
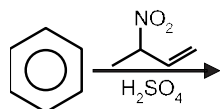

Ans. (3)

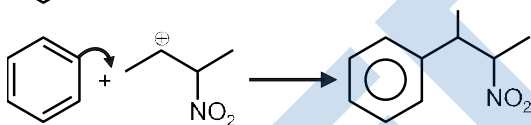
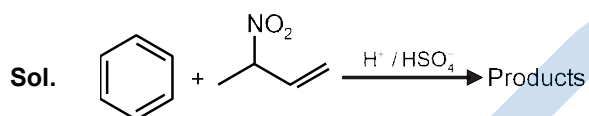

5. The correct sequence of reagents used in the preparation of 4-bromo-2-nitroethyl benzene from benzene is :

(1) $\text{HNO}_3/\text{H}_2\text{SO}_4$, $\text{Br}_2/\text{AlCl}_3$, $\text{CH}_3\text{COCl}/\text{AlCl}_3$, $\text{Zn-Hg}/\text{HCl}$

(2) $\text{Br}_2/\text{AlBr}_3$, $\text{CH}_3\text{COCl}/\text{AlCl}_3$, $\text{HNO}_3/\text{H}_2\text{SO}_4$, Zn/HCl

(3) $\text{CH}_3\text{COCl}/\text{AlCl}_3$, $\text{Br}_2/\text{AlBr}_3$, $\text{HNO}_3/\text{H}_2\text{SO}_4$, Zn/HCl

(4) $\text{CH}_3\text{COCl}/\text{AlCl}_3$, $\text{Zn-Hg}/\text{HCl}$, $\text{Br}_2/\text{AlBr}_3$, $\text{HNO}_3/\text{H}_2\text{SO}_4$

Ans. (4)

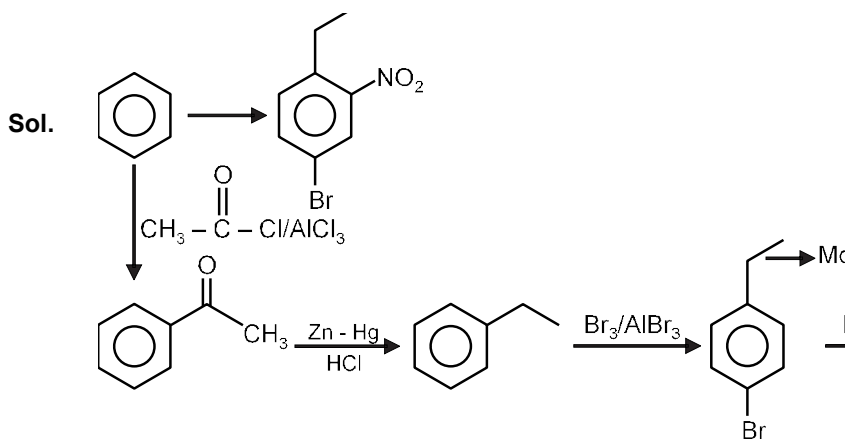

6. Water does not produce CO on reacting with:

- (1) CO₂ (2) C (3) CH₄ (4) C₃H₈

Ans. (1)

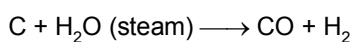
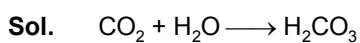

CH₄ + H₂O → CO + 3H₂ both reactions are carried out at 1270K temp. with Ni catalyst

C₃H₈ + H₂O → 3CO + H₂

Thus CO₂ does not produce CO.

7. The correct order of acid character of the following compounds is :

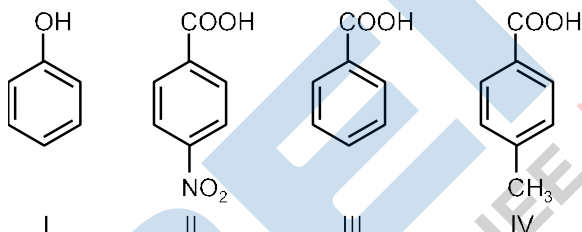

Options:

- (1) III > II > I > IV (2) IV > III > II > I (3) I > II > III > IV (4) II > III > IV > I

Ans. (4)

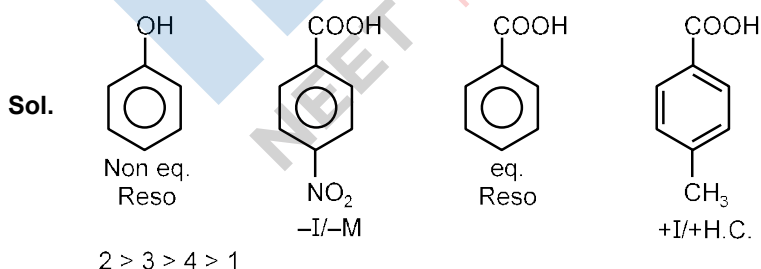

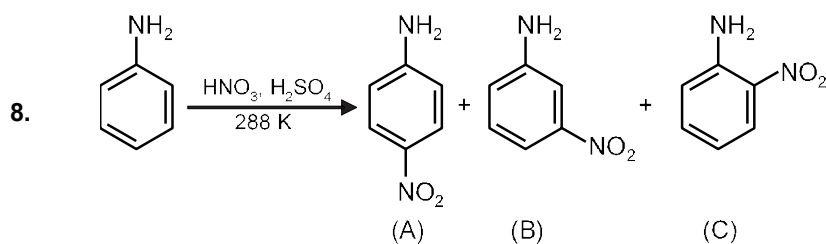

Correct statement about the given chemical reaction is :

- (1) group is ortho and para directive, so product (B) is not possible.
- (2) Reaction is possible and compound (B) will be the major product.
- (3) The reaction will form sulphonated product instead of nitration.
- (4) Reaction is possible and compound (A) will be major product.

Ans. (4)

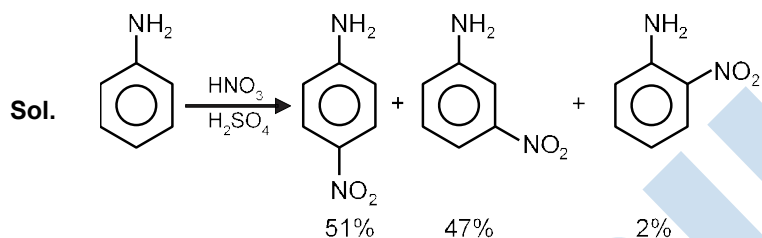

Due to formation of anilinium ion by acid base reaction m-product is form as considerable amount.

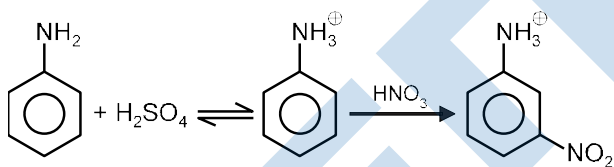

9. The correct order of bond dissociation enthalpy of halogens is :

- (1) $\text{Cl}_2 > \text{F}_2 > \text{Br}_2 > \text{I}_2$
- (2) $\text{I}_2 > \text{Br}_2 > \text{Cl}_2 > \text{F}_2$
- (3) $\text{Cl}_2 > \text{Br}_2 > \text{F}_2 > \text{I}_2$
- (4) $\text{F}_2 > \text{Cl}_2 > \text{Br}_2 > \text{I}_2$

Ans. (3)

Sol. Correct order of bond dissociation enthalpy of halogens is $\text{Cl}_2 > \text{Br}_2 > \text{F}_2 > \text{I}_2$.

Due to inter electronic repulsions F-F bond becomes weak and easily broken.

10. Given below are two statements :

Statement I : The pH of rain water is normally ~ 5.6 .

Statement II : If the pH of rain water drops below 5.6, it is called acid rain.

In the light of the above statements, choose the correct answer from the options given below:

- (1) Statement I is true but Statement II is false.
- (2) Both Statement I and Statement II are false.
- (3) Statement I is false but Statement II is true.
- (4) Both Statement I and Statement II are true.

Ans. (4)

Sol. Both statements are correct.

Normally rain water has pH of 5.6 due to the presence of H^+ ions formed by the reaction of rain water with carbon dioxide present in the atmosphere.

11. The major components of German Silver are :

- (1) Ge, Cu and Ag (2) Zn, Ni and Ag (3) Cu, Zn and Ni (4) Cu, Zn and Ag

Ans. (3)

Sol. Major components of German silver are:

Cu, Zn, Ni
(50%) (30%) (20%)

12. In which of the following order the given complex ions are arranged correctly with respect to their decreasing spin only magnetic moment ?

- (i) $[FeF_6]^{3-}$ (ii) $[Co(NH_3)_6]^{3+}$ (iii) $[NiCl_4]^{2-}$ (iv) $[Cu(NH_3)_4]^{2+}$
(1) (i) > (iii) > (iv) > (ii) (2) (ii) > (iii) > (i) > (iv) (3) (iii) > (iv) > (ii) > (i) (4) (ii) > (i) > (iii) > (iv)

Ans. (1)

Sol. Complex

(i) $[FeF_6]^{3-} Fe^{3+} \Rightarrow [Ar]3d^5, F^-$ is WFL

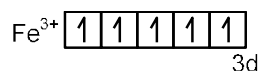

$n = 5, \quad \sqrt{35}$ B.M.

(ii) $[Co(NH_3)_6]^{3+} \Rightarrow Co^{3+}[Ar]3d^6, NH_3$ is SFL

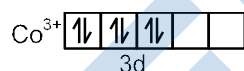

$n = 0, \mu = 0$

(iii) $[NiCl_4]^{2-} Ni^{2+} \Rightarrow [Ar]3d^8, Cl^- \rightarrow$ WFL

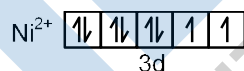

$n = 2, \quad \sqrt{8}$ B.M.

(iv) $[Cu(NH_3)_4]^{2+} Cu^{2+} \Rightarrow [Ar]3d^9, NH_3 \rightarrow$ SFL

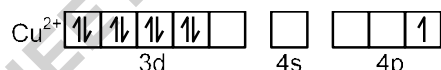

$n = 1, \quad \sqrt{3}$ B.M.

Thus correct order of spin only magnetic moment is (i) > (iii) > (iv) > (ii)

13. Which of the following compound is added to the sodium extract before addition of silver nitrate for testing of halogens?

- (1) Nitric acid (2) Ammonia (3) Hydrochloric acid (4) Sodium hydroxide

Ans. (1)

Sol. For testing of halogens, Nitric acid is added to the sodium extract because if CN^- or S^{2-} are present then they will be oxidised and removed before the test of halides.

14. Which one of the following statements is FALSE for hydrophilic sols ?

- (1) Their viscosity is of the order of that of H_2O .
 (2) The sols cannot be easily coagulated.
 (3) They do not require electrolytes for stability.
 (4) These sols are reversible in nature.

Ans. (1)

Sol. → Viscosity of hydrophilic sol > viscosity of H_2O

→ Hydrophilic sol is more stable so can't be easily coagulated.

→ Hydrophilic sols are reversible sols.

→ No electrolytes are required to stabilise hydrophilic sol.

15. The solubility of $\text{Ca}(\text{OH})_2$ in water is :

[Given : The solubility product of $\text{Ca}(\text{OH})_2$ in water = 5.5×10^{-6}]

- (1) 1.77×10^{-6} (2) 1.11×10^{-6} (3) 1.11×10^{-2} (4) 1.77×10^{-2}

Ans. (3)

Sol. $\text{Ca}(\text{OH})_2 \rightleftharpoons \text{Ca}^{2+}(\text{aq}) + 2\text{OH}^-(\text{aq})$

$$K_{sp} = s(2s)^2 \Rightarrow 5.5 \times 10^{-6} = 4s^3$$

$$s = \frac{5.5}{4} \times 10^{-6} \times \frac{1}{4} = 1.11 \times 10^{-2}$$

16. Given below are two statements :

Statement I : The identification of Ni^{2+} is carried out by dimethyl glyoxime in the presence of NH_4OH .

Statement II : The dimethyl glyoxime is a bidentate neutral ligand.

In the light of the above statements, choose the correct answer from the options given below:

- (1) Statement I is false but Statement II is true. (2) Both Statement I and Statement II are false.
 (3) Statement I is true but Statement II is false. (4) Both Statement I and Statement II are true.

Ans. (3)

Sol. Neutral dimethyl glyoxime does not act as ligand.

When Ni^{2+} reacts with dimethyl glyoxime in presence of NH_4OH , it produce dimethyl glyoximate then it form rozy red ppt.

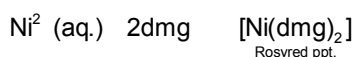

17. The major product of the following reaction is:

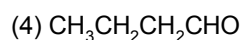
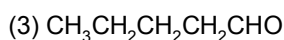
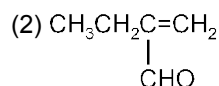
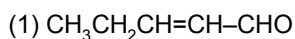
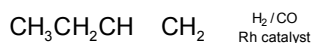

Ans. (3)

Sol. OXO PROCESS (Hydroformylation) :

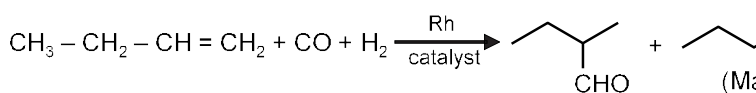

18. The method used for the purification of Indium is :

- (1) van Arkel method (2) liquation (3) zone refining (4) vapour phase refining

Ans. (3)

Sol. Zone refining is used for the purification of indium.

19. What is 'X' in the given reaction?

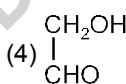
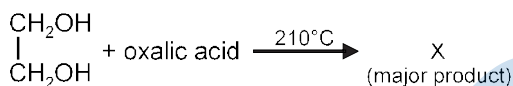

Ans. (1)

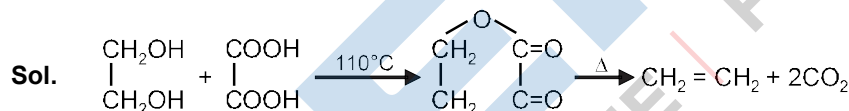

20. Given below are two statements :

Statement-I : α and β forms of sulphur can change reversibly between themselves with slow heating or slow cooling.

Statement-II : At room temperature the stable crystalline form of sulphur is monoclinic sulphur.

In the light of the above statements, choose the correct answer from the options given below:

- (1) Statement I is false but Statement II is true.
 (2) Both Statement I and Statement II are true.
 (3) Statement I is true but Statement II is false.
 (4) Both Statement I and Statement II are false.

Ans. (3)

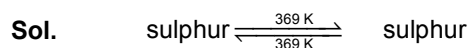

at room temperature α -sulphur (Rhombic) is most stable form.

Numeric Value Type

This Section contains **10 Numeric Value Type question**, out of 10 only 5 have to be done.

1. If a compound AB dissociates to the extent of 75% in an aqueous solution, the molality of the solution which shows a 2.5 K rise in the boiling point of the solution is _____ molal.

$$[K_b = 0.52\text{K kg mol}^{-1}]$$

Ans. (3)

Sol. $\alpha = 0.75$, $n = 2$

$$i = 1 - \alpha + n\alpha = 1 - 0.75 + 2 \times 0.75 = 1.75$$

$$\Delta T_b = iK_b m$$

$$\text{or, } 2.5 = 1.75 \times 0.52 \times m$$

$$\text{or, } m = \frac{2.5}{1.75 \times 0.52} = 2.74$$

\therefore nearest integer answer will be 3

2. The number of compound/s given below which contain/s $-\text{COOH}$ group is _____.

(A) Sulphanilic acid (B) Picric acid (C) Aspirin (D) Ascorbic acid

Ans. (1)

Sol. \longrightarrow COOH group present in

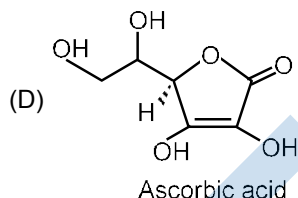
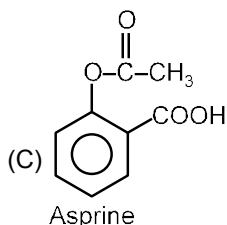
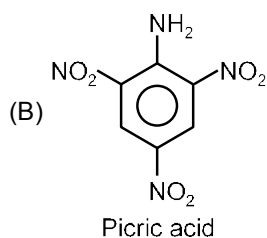
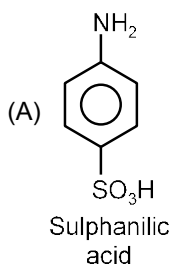

3. The rate constant of a reaction increases by five times on increase in temperature from 27°C to 52°C. The value of activation energy in kJ mol^{-1} is _____

$[R = 8.314 \text{ J K}^{-1} \text{ mol}^{-1}]$

Ans. (52)

Sol. $T_1 = 300\text{K}, T_2 = 325\text{K}, K_2 = 5K_1$

$$\ln \frac{K_2}{K_1} = \frac{E_a}{R} \left(\frac{1}{T_1} - \frac{1}{T_2} \right) \quad \text{or, } \ln 5 = \frac{E_a}{8.314} \left(\frac{1}{300} - \frac{1}{325} \right)$$

$$\text{or, } E_a = 0.7 \times 2.303 \times 8.314 \times 12 \times 325 = 52271 \text{ J} = 52.271 \text{ kJ}$$

4. Among the following, number of metal/s which can be used as electrodes in the photoelectric cell is _____.

(A) Li (B) Na (C) Rb (D) Cs

Ans. (1)

Sol. Cs is used as electrodes in the photoelectric cell.

5. The spin only magnetic moment of a divalent ion in aqueous solution (atomic number 29) is _____ BM.

Ans. (2)

Sol. $Z = 29$ (Cu)

Cu^{2+} form $[\text{Cu}(\text{H}_2\text{O})_4]^{2+}$ complex ion with H_2O .

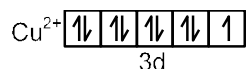
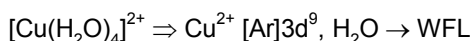

number of unpaired $e^- = 1$

$$\sqrt{1(1+2)} \text{ B.M.}$$

$$\sqrt{3} \Rightarrow 1.73 \text{ B.M.} \Rightarrow \text{round off ans.} \Rightarrow 2$$

6. Electromagnetic radiation of wavelength 663 nm is just sufficient to ionise the atom of metal A. The ionization energy of metal A in kJ mol^{-1} is _____.

$$[h = 6.63 \times 10^{-34} \text{ Js, } c = 3.00 \times 10^8 \text{ ms}^{-1}, N_A = 6.02 \times 10^{23} \text{ mol}^{-1}]$$

Ans. (180)

Sol. $E = \frac{hc}{\lambda} \frac{N_A}{1000}$

$$\frac{6.63 \times 10^{-34} \times 3 \times 10^8 \times 6.02 \times 10^{23}}{663 \times 10^{-9} \times 1000}$$

$$= 3 \times 6.02 \times 10 \text{ kJ}$$

$$= 180.6 \text{ kJ}$$

7. Consider titration of NaOH solution versus 1.25M oxalic acid solution. At the end point following burette readings were obtained.

(i) 4.5 mL

(ii) 4.5 mL

(iii) 4.4 mL

(iv) 4.4 mL

(v) 4.4 mL

If the volume of oxalic acid taken was 10.0 mL then the molarity of the NaOH solution is _____ M.

Ans. (6)

Sol. $V_{\text{NaOH}} = 4.4 \text{ ml}$

eq. of NaOH = eq. of $\text{H}_2\text{C}_2\text{O}_4$

$$\text{or, } M \times 4.4 \times 1 = 1.25 \times 10 \times 2$$

$$\text{or, } M = 5.68 \text{ M}$$

\therefore Nearest integer answer is 6

8. Five moles of an ideal gas at 293 K is expanded isothermally from an initial pressure of 2.1 MPa to 1.3 MPa against at constant external pressure 4.3 MPa. The heat transferred in this process is _____ kJ mol^{-1} . (Rounded-off to the nearest integer) [Use $R = 8.314 \text{ J mol}^{-1}\text{K}^{-1}$]

Ans. (15)

Sol. $n = 5, T = 293\text{K} = \text{const}, \Delta U = 0,$

$$P_1 = 2.1 \text{ MPa}, P_2 = 1.3 \text{ MPa}$$

$$P_{\text{ext}} = 4.3 \text{ MPa} = \text{const.}$$

$$W = P_{\text{ext}} (V_2 - V_1) = P_{\text{ext}} \left(\frac{nRT}{P_2} - \frac{nRT}{P_1} \right)$$

$$\text{or, } W = P_{\text{ext}} nRT \left(\frac{1}{P_2} - \frac{1}{P_1} \right)$$

$$4.3 \times 5 \times 8.314 \times 293 \left(\frac{1}{1.3} - \frac{1}{2.1} \right)$$

$$4.3 \times 5 \times 8.314 \times 293 \times \frac{2.1}{1.3} \times \frac{1.3}{2.1}$$

$$= -15347.7\text{J}$$

$$\text{or, } W = -15.35 \text{ kJ}$$

$$\Delta U^0 = q + W$$

$$\therefore q = -W$$

$$\text{or, } q = 15.35 \text{ kJ (for 5 moles)}$$

$$q / \text{mole} = \frac{15.35}{5} = 3 \text{ kJmol}^{-1}$$

9. Copper reduces NO_3 into NO and NO_2 depending upon the concentration of HNO_3 in solution. (Assuming fixed $[\text{Cu}^{2+}]$ and $P_{\text{NO}} = P_{\text{NO}_2}$), the HNO_3 concentration at which the thermodynamic tendency for reduction of NO_3 into NO and NO_2 by copper is same is 10^x M . The value of $2x$ is _____.

$$E^0_{\text{Cu}^{2+}/\text{Cu}} = 0.34 \text{ V}, E^0_{\text{NO}_3/\text{NO}} = 0.96 \text{ V}, E^0_{\text{NO}_3/\text{NO}_2} = 0.79 \text{ V and at } 298 \text{ K. } \frac{RT}{F} (2.303) = 0.059$$

Ans. (1)

Sol. If the partial pressure of NO and NO_2 gas is taken as 1 bar, then Answer is 4, else the question is bonus.



$$E^0_{\text{NO}_3/\text{NO}} = 0.96 \text{ V}$$



$$E^0_{\text{NO}_3/\text{NO}_2} = 0.79 \text{ V}$$

Let $[\text{HNO}_3] = y \Rightarrow [\text{H}^+] = y$ and $[\text{NO}_3] = y$ for same thermodynamic tendency

$$E_{\text{NO}_3/\text{NO}} = E_{\text{NO}_3/\text{NO}_2}$$

$$\text{or, } E^0_{\text{NO}_3/\text{NO}} - \frac{0.059}{3} \log \frac{P_{\text{NO}}}{y^4} = E^0_{\text{NO}_3/\text{NO}_2} - \frac{0.059}{1} \log \frac{P_{\text{NO}_2}}{y^2}$$

$$\text{or, } 0.96 - \frac{0.059}{3} \log \frac{P_{\text{NO}}}{y^4} = 0.79 - \frac{0.059}{1} \log \frac{P_{\text{NO}_2}}{y^2}$$

$$\text{or, } 0.17 = \frac{0.059}{1} \log \frac{P_{\text{NO}_2}}{y^2} - \frac{0.059}{3} \log \frac{P_{\text{NO}}}{y^4}$$

$$0.17 = \frac{0.0591}{1} \log \frac{P_{\text{NO}_2}}{y^2} - \frac{0.0591}{3} \log \frac{P_{\text{NO}}}{y^4}$$

$$0.17 = \frac{0.0591}{1} \log \frac{P_{\text{NO}_2}^3}{y^6} - \frac{0.0591}{3} \log \frac{P_{\text{NO}}}{y^4}$$

$$0.17 \frac{0.0591}{1} \log \frac{P_{NO}}{y^5} \log \frac{P_{NO_2}^3}{y^9}$$

$$0.17 \frac{0.0591}{1} \log \frac{P_{NO}}{y^5} \frac{y^9}{P_{NO_2}^3}$$

Assume $P_{NO} \approx P_{NO_2} = 1 \text{ bar}$

$$\frac{0.17}{0.059} \frac{3}{4} \log y^4 = 8.644$$

$$\log y = \frac{8.644}{4}$$

$$\log y = 2.161$$

$$y = 10^{2.16}$$

$$\therefore 2x = 2 \times 2.161 = 4.322$$

10. The unit cell of copper corresponds to a face centered cube of edge length 3.596 Å with one copper atom at each lattice point. The calculated density of copper in kg/m^3 is _____.

[Molar mass of Cu : 63.54 g ; Avogadro Number = 6.022×10^{23}]

Ans. (9077)

Sol. FCC,

$$d = \frac{Z M}{N_A a^3} = \frac{4 \times 63.54}{1000 \times 6.022 \times 10^{23} \times (3.596 \times 10^{-10})^3}$$

$$= 9076 \text{ kg/m}^3$$

PART C : MATHEMATICS

Single Choice Type

This section contains **20 Single choice questions**. Each question has 4 choices (1), (2), (3) and (4) for its answer, out of which **Only One** is correct.

1. Let A be a 3×3 matrix with $\det(A) = 4$. Let R_i denote the i^{th} row of A. If a matrix B is obtained by performing the operation $R_2 \rightarrow 2R_2 + 5R_3$ on 2A, then $\det(B)$ is equal to :

- (1) 16 (2) 80 (3) 128 (4) 64

Ans. (4)

Sol. $|A| = 4$

$$\Rightarrow |2A| = 2^3 \times 4 = 32$$

\therefore B is obtained by $R_2 \rightarrow 2R_2 + 5R_3$

$$\Rightarrow |B| = 2 \times 32 = 64$$

option (4)

2. The integral $\frac{e^{3\log_e 2x}}{e^{4\log_e x}} \frac{5e^{2\log_e 2x}}{5e^{3\log_e x} 7e^{2\log_e x}} dx, x > 0$, is equal to :

(where c is a constant of integration)

- (1) $\log_e |x^2 - 5x - 7| + c$ (2) $4 \log_e |x^2 - 5x - 7| + c$
 (3) $\frac{1}{4} \log_e |x^2 - 5x - 7| + c$ (4) $\log_e \sqrt{x^2 - 5x - 7} + c$

Ans. (2)

Sol. $\frac{e^{3\log_e 2x}}{e^{4\log_e x}} \frac{5e^{2\log_e 2x}}{5e^{3\log_e x} 7e^{2\log_e x}} dx, x > 0$
 $\frac{2x^3 \cdot 5 \cdot 2x^2}{x^4 \cdot 5x^3 \cdot 7x^2} dx = \frac{4x^2 \cdot 2x \cdot 5}{x^2 \cdot x^2 \cdot 5x \cdot 7} dx$
 $4 \frac{d(x^2 - 5x - 7)}{x^2 - 5x - 7} = 4 \log_e |x^2 - 5x - 7| + c$

option (2)

3. The shortest distance between the line $x - y = 1$ and the curve $x^2 = 2y$ is :

- (1) $\frac{1}{2}$ (2) $\frac{1}{2\sqrt{2}}$ (3) $\frac{1}{\sqrt{2}}$ (4) 0

Ans. (2)

Sol. Shortest distance between curves is always along common normal.

$\frac{dy}{dx}|_P$ slope of line = 1

$\Rightarrow x_0 = 1 \quad y_0 = \frac{1}{2}$

$P(1, \frac{1}{2})$

\therefore Shortest distance $= \frac{|1 - \frac{1}{2} - 1|}{\sqrt{1^2 + 1^2}} = \frac{1}{2\sqrt{2}}$

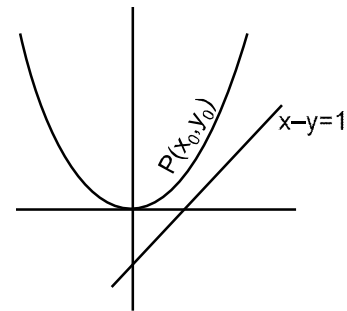

4. If $\alpha, \beta \in \mathbb{R}$ are such that $1 - 2i$ (here $i^2 = -1$) is a root of $z^2 + \alpha z + \beta = 0$, then $(\alpha - \beta)$ is equal to :

- (1) -3 (2) -7 (3) 7 (4) 3

Ans. (2)

Sol. $\because \alpha, \beta \in \mathbb{R} \Rightarrow$ other root is $1 + 2i$

$\alpha = -(\text{sum of roots}) = -(1 - 2i + 1 + 2i) = -2$

$\beta = \text{product of roots} = (1 - 2i)(1 + 2i) = 5$

$\therefore \alpha - \beta = -7$

5. A hyperbola passes through the foci of the ellipse $\frac{x^2}{25} + \frac{y^2}{16} = 1$ and its transverse and conjugate axes coincide with major and minor axes of the ellipse, respectively. If the product of their eccentricities is one, then the equation of the hyperbola is :

(1) $\frac{x^2}{9} - \frac{y^2}{25} = 1$ (2) $\frac{x^2}{9} - \frac{y^2}{16} = 1$ (3) $x^2 - y^2 = 9$ (4) $\frac{x^2}{9} - \frac{y^2}{4} = 1$

Ans. (2)

Sol. For ellipse $e_1 = \sqrt{1 - \frac{b^2}{a^2}} = \frac{3}{5}$

for hyperbola $e_2 = \frac{5}{3}$

Let hyperbola be

$$\frac{x^2}{a^2} - \frac{y^2}{b^2} = 1$$

\therefore it passes through $(3,0) \Rightarrow \frac{9}{a^2} = 1$

$$\Rightarrow a^2 = 9$$

$$\Rightarrow b^2 = a^2 (e^2 - 1)$$

$$9 \left(\frac{25}{9} - 1 \right) = 16$$

\therefore Hyperbola is

$$\frac{x^2}{9} - \frac{y^2}{16} = 1$$

... option 2.

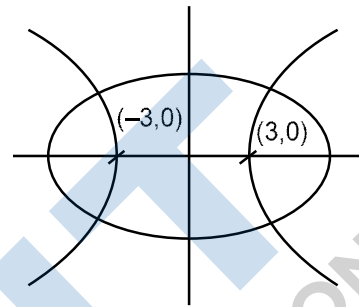

6. If $0 < x, y < \pi$ and $\cos x + \cos y - \cos(x + y) = \frac{3}{2}$, then $\sin x + \cos y$ is equal to :

(1) $\frac{1}{2}$ (2) $\frac{1 - \sqrt{3}}{2}$ (3) $\frac{\sqrt{3}}{2}$ (4) $\frac{1 + \sqrt{3}}{2}$

Ans. (2)

Sol. $\cos x + \cos y - \cos(x + y) = \frac{3}{2}$

$$\cos^2 \frac{x+y}{2} - \cos^2 \frac{x-y}{2} - \cos \frac{x+y}{2} \cos \frac{x-y}{2} = \frac{1}{4} \cos^2 \frac{x+y}{2} - \frac{1}{4} \sin^2 \frac{x-y}{2} = 0$$

$$\cos \frac{x+y}{2} = \frac{1}{2} \cos \frac{x-y}{2} \quad \frac{1}{4} \sin^2 \frac{x-y}{2} = 0$$

$$\sin \frac{x+y}{2} = 0 \text{ and } \cos \frac{x+y}{2} = \frac{1}{2} \cos \frac{x-y}{2}$$

$$x = y \text{ and } \cos x = \frac{1}{2} \cos y$$

$$\sin x = \frac{\sqrt{3}}{2}$$

$$\sin x \cos y = \frac{1 - \sqrt{3}}{2}$$

7. A plane passes through the points A(1, 2, 3), B(2, 3, 1) and C(2, 4, 2). If O is the origin and P is (2, -1, 1), then the projection of \overline{OP} on this plane is of length :

- (1) $\sqrt{\frac{2}{7}}$ (2) $\sqrt{\frac{2}{3}}$ (3) $\sqrt{\frac{2}{11}}$ (4) $\sqrt{\frac{2}{5}}$

Ans. (3)

Sol.

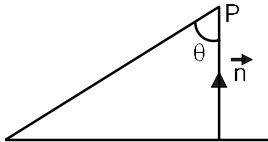

Normal to plane $\vec{n} = \begin{vmatrix} \hat{i} & \hat{j} & \hat{k} \\ 1 & 1 & 2 \\ 0 & 1 & 1 \end{vmatrix}$

$$3\hat{i} - \hat{j} + \hat{k}$$

$$\overline{OP} = 2\hat{i} - \hat{j} + \hat{k}$$

$$\cos \theta = \frac{6 - 1 + 1}{\sqrt{6}\sqrt{11}} = \frac{6}{\sqrt{66}} \quad \sin \theta = \frac{\sqrt{2}}{\sqrt{66}}$$

Projection of \overline{OP} on plane $|\overline{OP}| \sin \theta = \sqrt{\frac{2}{11}}$

8. In a group of 400 people, 160 are smokers and non-vegetarian; 100 are smokers and vegetarian and the remaining 140 are non-smokers and vegetarian. Their chances of getting a particular chest disorder are 35%, 20% and 10% respectively. A person is chosen from the group at random and is found to be suffering from the chest disorder. The probability that the selected person is a smoker and non-vegetarian is :

- (1) $\frac{7}{45}$ (2) $\frac{14}{45}$ (3) $\frac{28}{45}$ (4) $\frac{8}{45}$

Ans. (3)

Sol. Consider following events

A : Person chosen is a smoker and non vegetarian.

B : Person chosen is a smoker and vegetarian.

C : Person chosen is a non-smoker and vegetarian.

E : Person chosen has a chest disorder

Given

$$P A \frac{160}{400} \quad P B \frac{100}{400} \quad P C \frac{140}{400}$$

$$P \frac{E}{A} \frac{35}{100} \quad P \frac{E}{B} \frac{20}{100} \quad P \frac{E}{C} \frac{10}{100}$$

To find

$$P \frac{A}{E} = \frac{P A P \frac{E}{A}}{P A P \frac{E}{A} + P B P \frac{E}{B} + P C P \frac{E}{C}}$$

$$\frac{\frac{160}{400} \cdot \frac{35}{100}}{\frac{160}{400} \cdot \frac{35}{100} + \frac{100}{400} \cdot \frac{20}{100} + \frac{140}{400} \cdot \frac{10}{100}}$$

$$\frac{28}{45} \text{ option (3)}$$

9. cosec $2 \cot^{-1}(5)$ $\cos^{-1} \frac{4}{5}$ is equal to :

(1) $\frac{56}{33}$

(2) $\frac{65}{56}$

(3) $\frac{65}{33}$

(4) $\frac{75}{56}$

Ans. (2)

Sol. cosec $2 \tan^{-1} \frac{1}{5}$ $\tan^{-1} \frac{3}{4}$

$$\text{cosec } \tan^{-1} \frac{5}{12} \tan^{-1} \frac{3}{4}$$

$$\text{cosec } \tan^{-1} \frac{56}{33} \frac{65}{56} \text{ option (2)}$$

10. If the curve $x^2 + 2y^2 = 2$ intersects the line $x + y = 1$ at two points P and Q, then the angle subtended by the line segment PQ at the origin is :

(1) $\frac{1}{2} \tan^{-1} \frac{1}{3}$

(2) $\frac{1}{2} \tan^{-1} \frac{1}{3}$

(3) $\frac{1}{2} \tan^{-1} \frac{1}{4}$

(4) $\frac{1}{2} \tan^{-1} \frac{1}{4}$

Ans. (4)

Sol. Homogenising

$$x^2 + 2y^2 - 2(x + y)^2 = 0$$

$$\Rightarrow -x^2 - 4xy = 0 \Rightarrow x^2 + 4xy = 0$$

Lines are $x = 0$ and $y = \frac{x}{4}$

\therefore Angle between lines $\frac{1}{2} \tan^{-1} \frac{1}{4}$

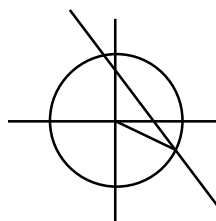

11. The contrapositive of the statement "If you will work, you will earn money" is :

- (1) You will earn money, if you will not work
- (2) If you will earn money, you will work
- (3) If you will not earn money, you will not work
- (4) To earn money, you need to work

Ans. (3)

Sol. Contrapositive of $p \rightarrow q$ is $\sim q \rightarrow \sim p$

\Rightarrow If you will not earn money, you will not work.

12. A function $f(x)$ is given by $f(x) = \frac{5^x}{5^x - 5}$, then the sum of the series

$f\left(\frac{1}{20}\right) + f\left(\frac{2}{20}\right) + f\left(\frac{3}{20}\right) + \dots + f\left(\frac{39}{20}\right)$ is equal to :

- (1) $\frac{19}{2}$
- (2) $\frac{49}{2}$
- (3) $\frac{29}{2}$
- (4) $\frac{39}{2}$

Ans. (4)

Sol. $f(x) = \frac{5^x}{5^x - 5}$ $f(2-x) = \frac{5^{2-x}}{5^{2-x} - 5}$

$$f(x) + f(2-x) = 1$$

$$f\left(\frac{1}{20}\right) + f\left(\frac{2}{20}\right) + \dots + f\left(\frac{39}{20}\right)$$

$$+ f\left(\frac{19}{20}\right) + f\left(\frac{21}{20}\right) + \dots + f\left(\frac{20}{20}\right)$$

$$= 19 \times \frac{1}{2} + \frac{39}{2}$$

13. If for the matrix, $A = \begin{pmatrix} 1 & \alpha \\ \beta & 1 \end{pmatrix}$, $AA^T = I_2$, then the value of $\alpha^4 + \beta^4$ is :

- (1) 4
- (2) 2
- (3) 3
- (4) 1

Ans. (4)

Sol. $A = \begin{pmatrix} 1 & \alpha \\ \beta & 1 \end{pmatrix}$ $AA^T = I_2$

$$\begin{pmatrix} 1 & \alpha \\ \beta & 1 \end{pmatrix} \begin{pmatrix} 1 & \beta \\ \alpha & 1 \end{pmatrix} = \begin{pmatrix} 1 & 0 \\ 0 & 1 \end{pmatrix}$$

$$\begin{pmatrix} 1 + \alpha\beta & \alpha + \beta \\ \alpha\beta + 1 & \alpha + \beta \end{pmatrix} = \begin{pmatrix} 1 & 0 \\ 0 & 1 \end{pmatrix}$$

$$\Rightarrow \alpha^2 = 0 \text{ \& } \beta^2 = 1$$

$$\therefore \alpha^4 + \beta^4 = 1$$

14. The minimum value of $f(x) = a^{ax} + a^{1-ax}$, where $a, x \in \mathbb{R}$ and $a > 0$, is equal to :

- (1) $2a$ (2) $2\sqrt{a}$ (3) $a \frac{1}{a}$ (4) $a + 1$

Ans. (2)

Sol. A.M. \geq G.M.

$$f(x) = a^{a^x} \cdot a^{1/a^x} \cdot a^{a^x} \cdot \frac{a}{a^{a^x}} = 2\sqrt{a}$$

15. If $I_n = \int_0^{\pi/4} \cot^n x \, dx$, then :

- (1) $\frac{I_2}{I_4}, \frac{I_3}{I_5}, \frac{I_4}{I_6}$ are in G.P. (2) $I_2 + I_4, I_3 + I_5, I_4 + I_6$ are in A.P.
 (3) $I_2 + I_4, (I_3 + I_5)^2, I_4 + I_6$ are in G.P. (4) $\frac{I_2}{I_4}, \frac{I_3}{I_5}, \frac{I_4}{I_6}$ are in A.P.

Ans. (4)

Sol. $I_n = \int_0^{\pi/4} \cot^n x \, dx = \int_0^{\pi/4} \cot^{n-2} x \cdot \operatorname{cosec}^2 x \cdot 1 \, dx$

$$= \frac{\cot^{n-1} x}{n-1} \Big|_0^{\pi/4} - I_{n-2}$$

$$= \frac{1}{n-1} - I_{n-2}$$

$$I_n - I_{n-2} = \frac{1}{n-1}$$

$$I_2 - I_4 = \frac{1}{3}$$

$$I_3 - I_5 = \frac{1}{4}$$

$$I_4 - I_6 = \frac{1}{5}$$

$\frac{I_2}{I_4}, \frac{I_3}{I_5}, \frac{I_4}{I_6}$ are in A.P.

16. $\lim_n \left(\frac{1}{n} - \frac{n}{n^2-1} + \frac{n}{n^2-2^2} - \dots - \frac{n}{2n^2-1} \right)$ is equal to :

- (1) $\frac{1}{2}$ (2) 1 (3) $\frac{1}{3}$ (4) $\frac{1}{4}$

Ans. (1)

Sol. $\lim_n \left(\frac{1}{n} - \frac{n}{n^2-1} + \frac{n}{n^2-2^2} - \dots - \frac{n}{2n^2-1} \right)$

$$\lim_{n \rightarrow \infty} \frac{n^{n-1}}{n^n} = \lim_{n \rightarrow \infty} \frac{n^{n-1}}{n^n} = \lim_{n \rightarrow \infty} \frac{1}{n} = 0$$

$$\lim_{n \rightarrow \infty} \frac{1}{n} = 0$$

$$\lim_{n \rightarrow \infty} \frac{1}{n} = 0$$

17. Let A be a set of all 4-digit natural numbers whose exactly one digit is 7. Then the probability that a randomly chosen element of A leaves remainder 2 when divided by 5 is :

- (1) $\frac{2}{9}$ (2) $\frac{122}{297}$ (3) $\frac{97}{297}$ (4) $\frac{1}{5}$

Ans. (3)

Sol. $n(s) = n(\text{when 7 appears on thousands place}) + n(\text{7 does not appear on thousands place})$

$$= 9 \times 9 \times 9 + 8 \times 9 \times 9 \times 3$$

$$= 33 \times 9 \times 9$$

$n(E) = n(\text{last digit 7 \& 7 appears once}) + n(\text{last digit 2 when 7 appears once})$

$$= 8 \times 9 \times 9 + (9 \times 9 + 8 \times 9 \times 2)$$

$$P(E) = \frac{8 \times 9 \times 9 + 9 \times 9 + 8 \times 9 \times 2}{33 \times 9 \times 9} = \frac{97}{297}$$

18. Let α and β be the roots of $x^2 - 6x - 2 = 0$. If $a_n = \alpha^n - \beta^n$ for $n \geq 1$, then the value of $\frac{a_{10} - 2a_8}{3a_9}$ is :

- (1) 2 (2) 1 (3) 4 (4) 3

Ans. (1)

Sol. $\alpha^2 - 6\alpha - 2 = 0$

$$\alpha^{10} - 6\alpha^9 - 2\alpha^8 = 0$$

Similarly $\beta^{10} - 6\beta^9 - 2\beta^8 = 0$

$$(\alpha^{10} - \beta^{10}) - 6(\alpha^9 - \beta^9) - 2(\alpha^8 - \beta^8) = 0$$

$$\Rightarrow a_{10} - 6a_9 - 2a_8 = 0$$

$$\frac{a_{10} - 2a_8}{3a_9} = 2$$

19. Let x denote the total number of one-one functions from a set A with 3 elements to a set B with 5 elements and y denote the total number of one-one functions from the set A to the set A × B. Then :

- (1) $y = 273x$ (2) $2y = 91x$ (3) $y = 91x$ (4) $2y = 273x$

Ans. (2)

Sol. $x = {}^5C_3 \times 3! = 60$

$$y = {}^{15}C_3 \times 3! = 15 \times 14 \times 13 = 30 \times 91$$

$\therefore 2y = 91x$

20. The following system of linear equations

$2x + 3y + 2z = 9$

$3x + 2y + 2z = 9$

$x - y + 4z = 8$

(1) has a solution (α, β, γ) satisfying $\alpha + \beta^2 + \gamma^3 = 12$

(2) has infinitely many solutions

(3) does not have any solution

(4) has a unique solution

Ans. (4)

Sol. $2x + 3y + 2z = 9 \quad \dots(1)$

$3x + 2y + 2z = 9 \quad \dots(2)$

$x - y + 4z = 8 \quad \dots(3)$

$(1) - (2) \Rightarrow -x + y = 0 \Rightarrow x - y = 0$

from (3) $4z = 8 \Rightarrow z = 2$

from (1) $2x + 3y = 5$

$\Rightarrow x = y = 1$

\therefore system has unique solution

Numeric Value Type

This Section contains 10 Numeric Value Type question, out of 10 only 5 have to be done.

1. The total number of two digit numbers 'n', such that $3^n + 7^n$ is a multiple of 10, is _____.

Ans. (45)

Sol. for $3^n + 7^n$ to be divisible by 10

n can be any odd number

\therefore Number of odd two digit numbers = 45

2. A function f is defined on $[-3, 3]$ as

$$f(x) = \begin{cases} \min\{|x|, 2 - x^2\}, & -2 \leq x \leq 2 \\ |x|, & 2 < |x| \leq 3 \end{cases}$$

where $[x]$ denotes the greatest integer $\leq x$. The number of points, where f is not differentiable in $(-3, 3)$ is _____.

Ans. (5)

Sol. $f(x) = \min\{|x|, 2 - x^2\}$, $2 - x^2 \geq |x|$
 $|x| \leq 2 - x^2$, $2 - |x| \geq 3$

$\Rightarrow x \in [-3, -2] \cup [2, 3]$

Number of points of non-differentiability in

$(-3, 3) = 5$

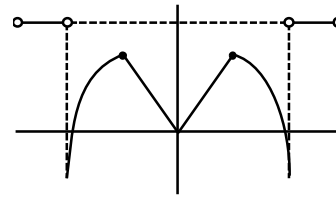

3. Let $\vec{a} = \hat{i} + \hat{j} + 3\hat{k}$ and $\vec{b} = 3\hat{i} + \hat{j} + \hat{k}$. If the area of the parallelogram whose adjacent sides are represented by the vectors \vec{a} and \vec{b} is $8\sqrt{3}$ square units, then α is equal to _____:

Ans. (2)

Sol. $\vec{a} = \hat{i} + \hat{j} + 3\hat{k}$

$\vec{b} = 3\hat{i} + \hat{j} + \hat{k}$

area of parallelogram $|\vec{a} \times \vec{b}| = 8\sqrt{3}$.

$$\vec{a} \times \vec{b} = \begin{vmatrix} \hat{i} & \hat{j} & \hat{k} \\ 1 & 1 & 3 \\ 3 & 1 & 1 \end{vmatrix} = \hat{i}(1 - 9) - \hat{j}(1 - 9) + \hat{k}(1 - 3)$$

$|\vec{a} \times \vec{b}| = \sqrt{64 + 32 + 4} = 8\sqrt{3}$

$\Rightarrow 2 + \alpha^2 = 6 \Rightarrow \alpha^2 = 4$

$\alpha = 2$

4. If the remainder when x is divided by 4 is 3, then the remainder when $(2020 + x)^{2022}$ is divided by 8 is _____.

Ans. (1)

Sol. $x = 4k + 3$

$\therefore (2020 + x)^{2022} = (2020 + 4k + 3)^{2022}$

$= (4(505 + k) + 3)^{2022}$

$= (4\lambda + 3)^{2022} = (16\lambda^2 + 24\lambda + 9)^{1011}$

$= (8(2\lambda^2 + 3\lambda + 1) + 1)^{1011}$

$= (8p + 1)^{1011}$

\therefore Remainder when divided by 8 = 1

5. If the curves $x = y^4$ and $xy = k$ cut at right angles, then $(4k)^6$ is equal to _____.

Ans. (4)

Sol. $x = y^4$, $xy = k$

for intersection $y^5 = k$..(1)

Also $x = y^4$

$$1 - 4y^3 \frac{dy}{dx} = \frac{dy}{dx} - \frac{1}{4y^3}$$

for $xy = k \quad x = \frac{k}{y}$

$$1 - \frac{k}{y^2} \frac{dy}{dx}$$

$$\frac{dy}{dx} = \frac{y^2}{k}$$

∴ Curve cut orthogonally

$$\frac{1}{4y^3} = \frac{y^2}{k} \quad 1$$

$$y = \frac{1}{4k}$$

∴ from (1) $y^5 = k$

$$\frac{1}{4k^5} = k$$

$$\Rightarrow 4 = (4k)^6$$

6. A line is a common tangent to the circle $(x - 3)^2 + y^2 = 9$ and the parabola $y^2 = 4x$. If the two points of contact (a, b) and (c, d) are distinct and lie in the first quadrant, then $2(a + c)$ is equal to _____.

Ans. (9)

Sol. Let coordinate of point $A(t^2, 2t) \quad (\because a = 1)$

equation of tangent at point A

$$yt = x + t^2$$

$$x - ty + t^2 = 0$$

centre of circle $(3, 0)$

Now PD = radius $(0,0) (3,0)$

$$\left| \frac{3 - 0 + t^2}{\sqrt{1 + t^2}} \right| = 3$$

$$(3 + t^2)^2 = 9(1 + t^2)$$

$$9 + t^4 + 6t^2 = 9 + 9t^2$$

$$t = 0, \sqrt{3}, \sqrt{3}$$

So point A $3, 2\sqrt{3}$

$$\Rightarrow a = 3, b = 2\sqrt{3}$$

(Since it lies in first quadrant)

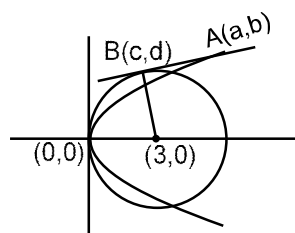

For point B which is foot of perpendicular from centre (3, 0) to the tangent $x = \sqrt{3} - 3 = 0$

$$\frac{c - 3}{1} = \frac{d - 0}{\sqrt{3}} = \frac{(3 - 0) - 3}{4}$$

$$c = \frac{3}{2} \quad d = \frac{3\sqrt{3}}{2}$$

$$2 \cdot \frac{3}{2} - 3 = 9$$

7. If $\lim_{x \rightarrow 0} \frac{ax - e^{4x} - 1}{ax - e^{4x} - 1}$ exists and is equal to b, then the value of $a - 2b$ is _____.

Ans. (5)

Sol. $\lim_{x \rightarrow 0} \frac{ax - e^{4x} - 1}{ax - e^{4x} - 1} = \frac{0}{0}$

$$\lim_{x \rightarrow 0} \frac{ax - e^{4x} - 1}{ax - 4x} \quad \boxed{\text{Use } \lim_{x \rightarrow 0} \frac{e^{4x} - 1}{4x} = 1}$$

Apply L'Hospital Rule

$$\lim_{x \rightarrow 0} \frac{a - 4e^{4x}}{8ax} = \frac{a - 4}{0} \text{ form}$$

limit exists only when $a - 4 = 0 \Rightarrow a = 4$

$$\lim_{x \rightarrow 0} \frac{4 - 4e^{4x}}{32x}$$

$$\lim_{x \rightarrow 0} \frac{1 - e^{4x}}{8x} = \frac{0}{0}$$

$$\lim_{x \rightarrow 0} \frac{e^{4x} - 4}{8} = \frac{1}{2} \quad b = \frac{1}{2}$$

$$a - 2b = 4 - 2 \cdot \frac{1}{2}$$

$$= 5$$

8. If the curve, $y = y(x)$ represented by the solution of the differential equation $(2xy^2 - y)dx + xdy = 0$, passes through the intersection of the lines, $2x - 3y = 1$ and $3x + 2y = 8$, then $|y(1)|$ is equal to _____.

Ans. (1)

Sol. $(2xy^2 - y)dx + xdy = 0$

$$2xy^2 dx - y dx + x dy = 0$$

$$2x dx - \frac{y dx - x dy}{y^2} = d \frac{x}{y}$$

Now integrate

$$x^2 = \frac{x}{y} + c$$

Now point of intersection of lines are (2, 1)

$$4 = \frac{2}{1} + c \quad c = 2$$

$$x^2 = \frac{x}{y} + 2$$

Now $y(1) = -1$

$$\Rightarrow |y(1)| = 1$$

9. The value of $\int_2^2 (3x^2 - 3x - 6) dx$ is _____.

Ans. (19)

Sol. $\int_2^2 (3x^2 - 3x - 6) dx$

$$= \int_2^2 (3x^2 - 3x - 6) dx$$

$$= 3 \int_2^1 x^2 dx - 3 \int_2^1 x dx - 6 \int_2^1 dx$$

$$= 3 \left[\frac{x^3}{3} - \frac{x^2}{2} - 2x \right]_2^1 = \left[x^3 - \frac{x^2}{2} - 4x \right]_2^1$$

$$= 3 - 7 - \frac{2}{3}$$

$$= 19$$

10. A line 'l' passing through origin is perpendicular to the lines

$$l_1: \vec{r} = (3 - t)\hat{i} + (1 - 2t)\hat{j} + (4 - 2t)\hat{k}$$

$$l_2: \vec{r} = (3 - 2s)\hat{i} + (3 - 2s)\hat{j} + (2 - s)\hat{k}$$

If the co-ordinates of the point in the first octant on 'l' at a distance of $\sqrt{17}$ from the point of intersection of 'l' and 'l₁' are (a, b, c), then 18(a + b + c) is equal to _____.

Ans. (44)

Sol. $l_1: \vec{r} = (3 - t)\hat{i} + (1 - 2t)\hat{j} + (4 - 2t)\hat{k}$

$$l_2: \vec{r} = (3 - 2s)\hat{i} + (3 - 2s)\hat{j} + (4 - s)\hat{k}$$

DR of $l_1 \equiv (1, 2, 2)$

DR of $l_2 \equiv (2, 2, 1)$

DR of l (line \perp to l_1 & l_2) = (-2, 3, -2)

$$l: \vec{r} = 2\hat{i} + 3\hat{j} + 2\hat{k}$$

for intersection of l & l_1

$$3 + t = -2\mu$$

$$-1 + 2t = 3\mu$$

$$4 + 2t = -2\mu$$

$$\Rightarrow t = -1 \text{ \& } \lambda = -1$$

\therefore Point of intersection $P \equiv (2, -3, 2)$

Let point on l_2 be $Q (3 + 2s, 3 + 2s, 2 + s)$

Given $PQ = \sqrt{17} \Rightarrow (PQ)^2 = 17$

$$\Rightarrow (2s + 1)^2 + (6 + 2s)^2 + (s)^2 = 17$$

$$\Rightarrow 9s^2 + 28s + 20 = 0$$

$$s = 2, \frac{10}{9}$$

$s \neq -2$ as point lies on 1st octant.

a $3, 2, \frac{10}{9}, \frac{7}{9}$

b $3, 2, \frac{10}{9}, \frac{7}{9}$

c $2, \frac{10}{9}, \frac{8}{9}$

18 a b c 18 $\frac{22}{9}$ 44